



Fundamental of Petroleum Engineering

Eng. Mohamed Mamdouh Aboelenin

Content



- Petroleum geology
- Drilling fundamentals
- Production operations
- Artificial lift engineering
- Well intervention

What Does Petroleum Mean?



Petroleum literally means ‘rock oil’. The word comes from the Greek word ‘petra’ (meaning ‘**rock**’) and the Latin word ‘oleum’ (meaning ‘**oil**’).



Well life cycle

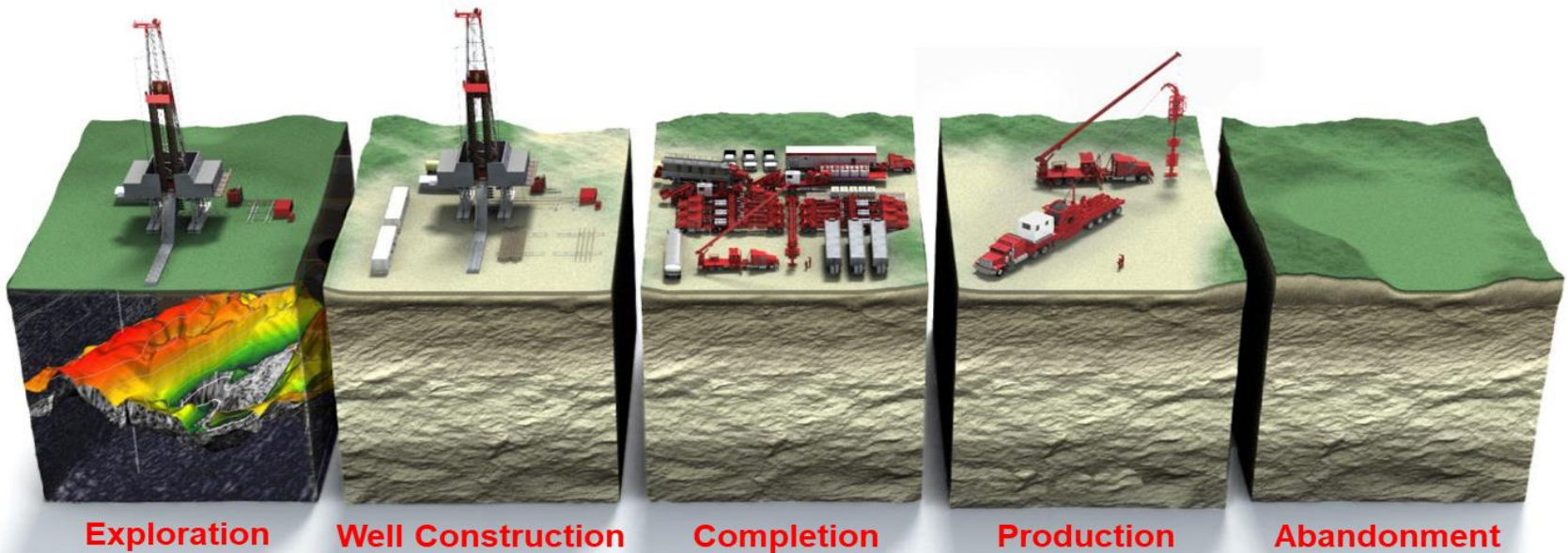

Exploration

Well Construction

Completion

Production

Abandonment

Concession Agreements



Concession agreements in the oil and gas industry refer to contracts between a government and a company (or consortium) granting the company rights to explore for, develop, and produce hydrocarbons in a specified area.

There are several types of concession agreements, depending on the fiscal regime and the level of government control

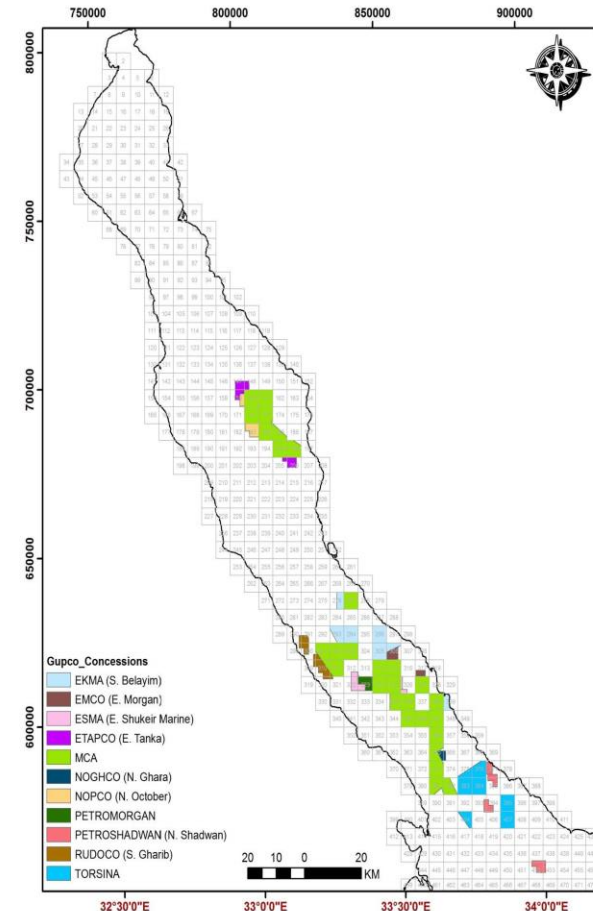

Concession Agreements types



1. Royalty and Taxes
2. Production sharing
3. Joint venture Agreements
4. Turn Key (Service Agreement

Petroleum engineers' types



1. Reservoir engineers.
2. Drilling engineers
3. Production engineers,
4. subsurface engineers

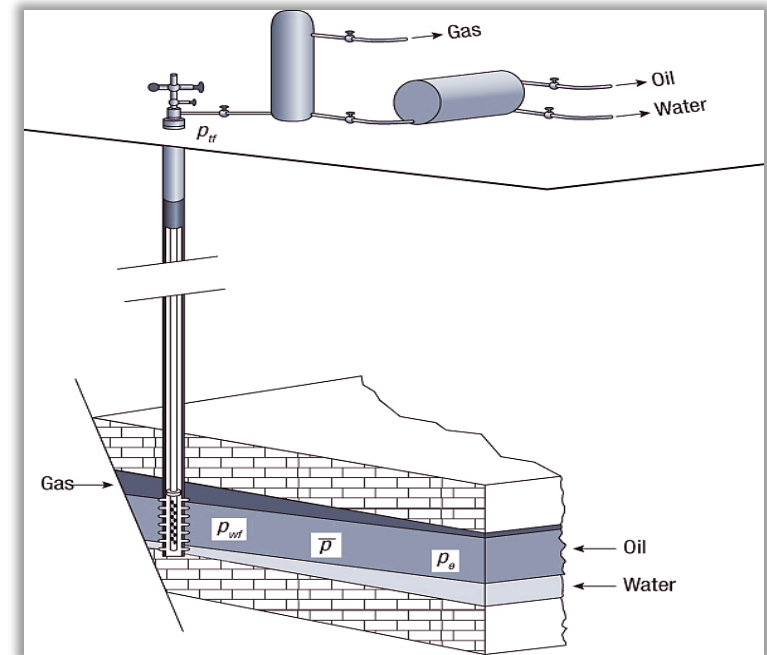

Rock types

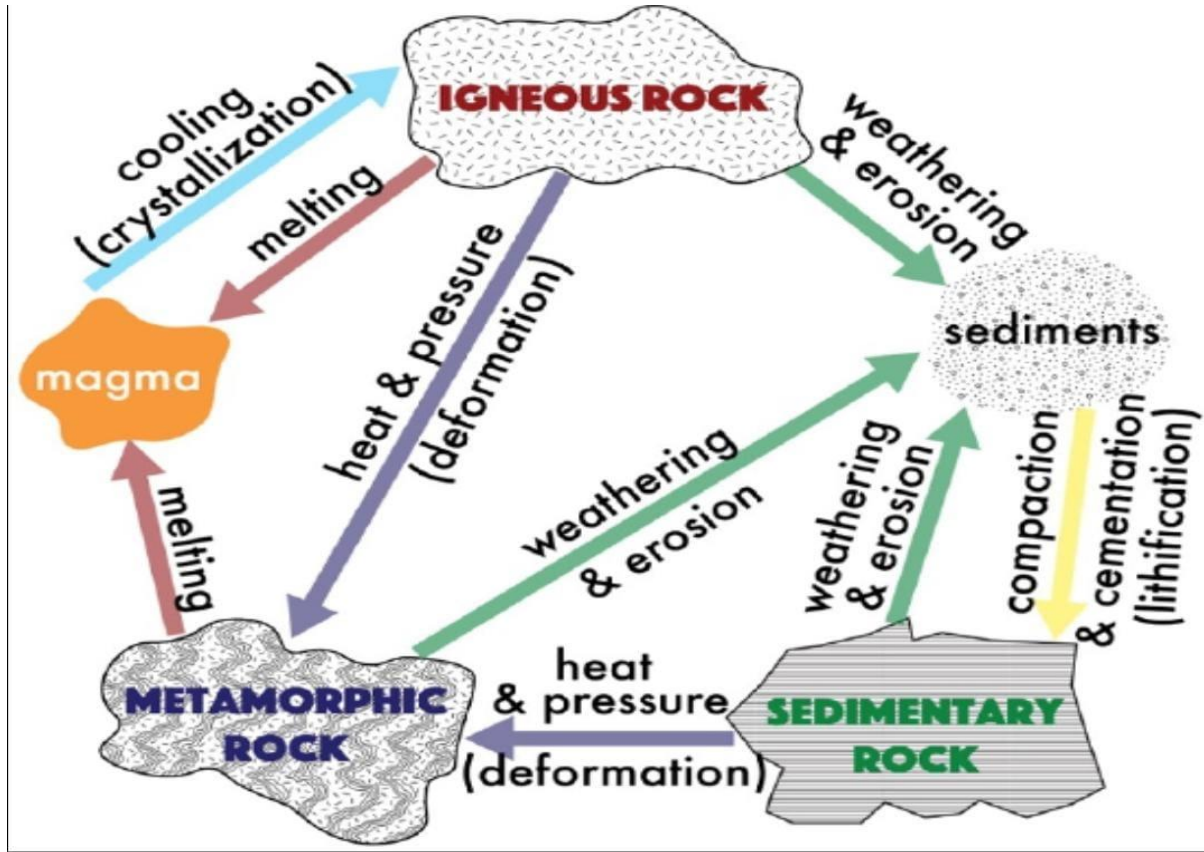

What Made Oil

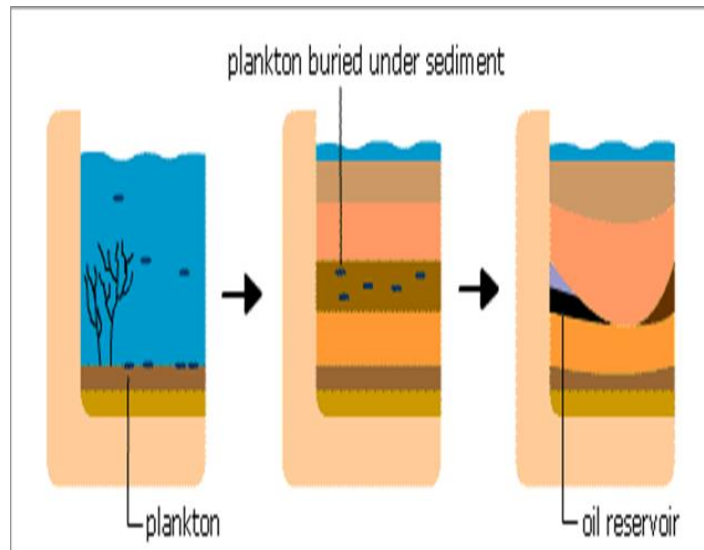
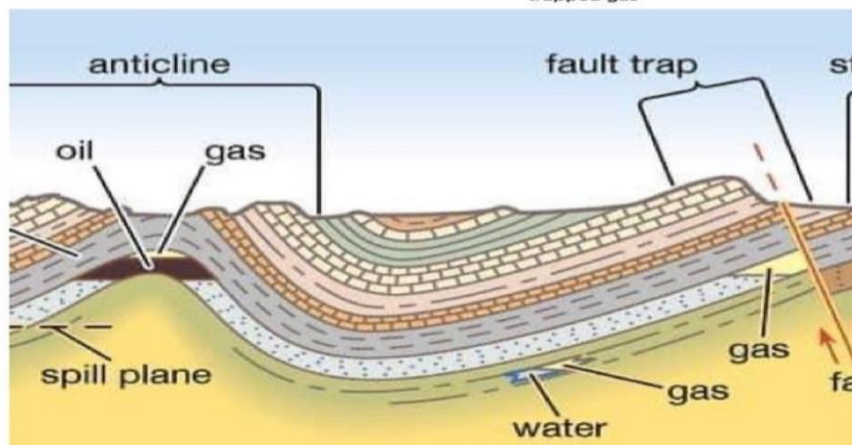
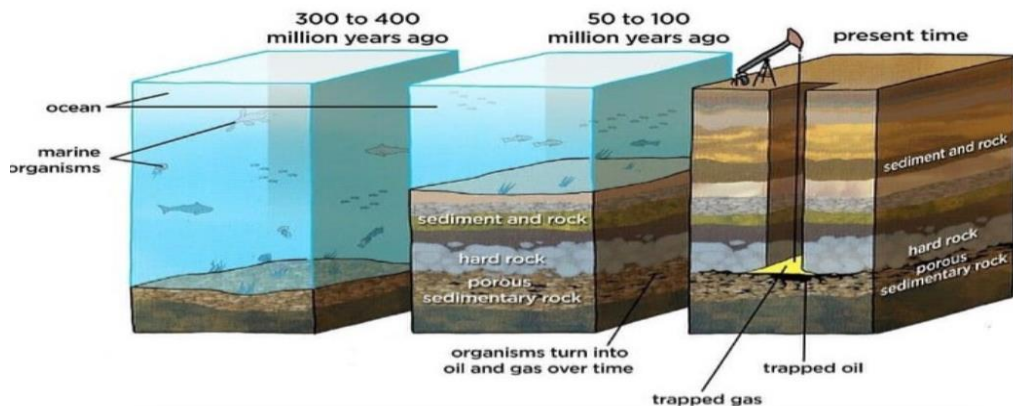

Parameters Controlling Petroleum Occurrence



Petroleum system

Time of oil Migration after the formation of traps

Elements

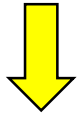

Source rock

Reservoir Rock

Trap

Seal Rock

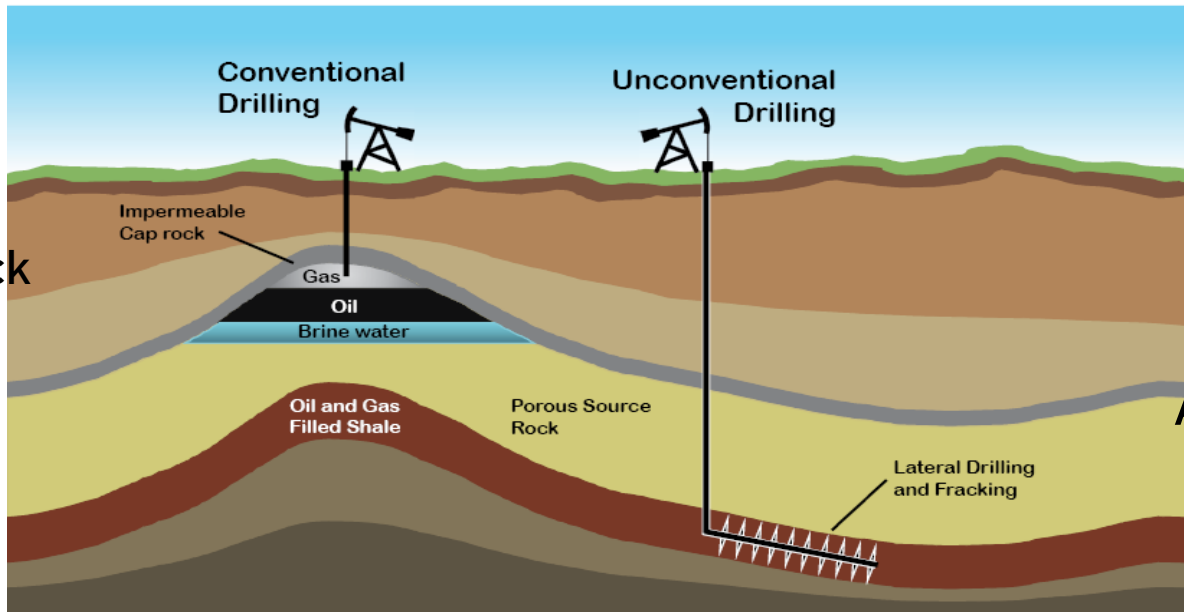

Processes



Maturity

Migration

Accumulation

Preservation

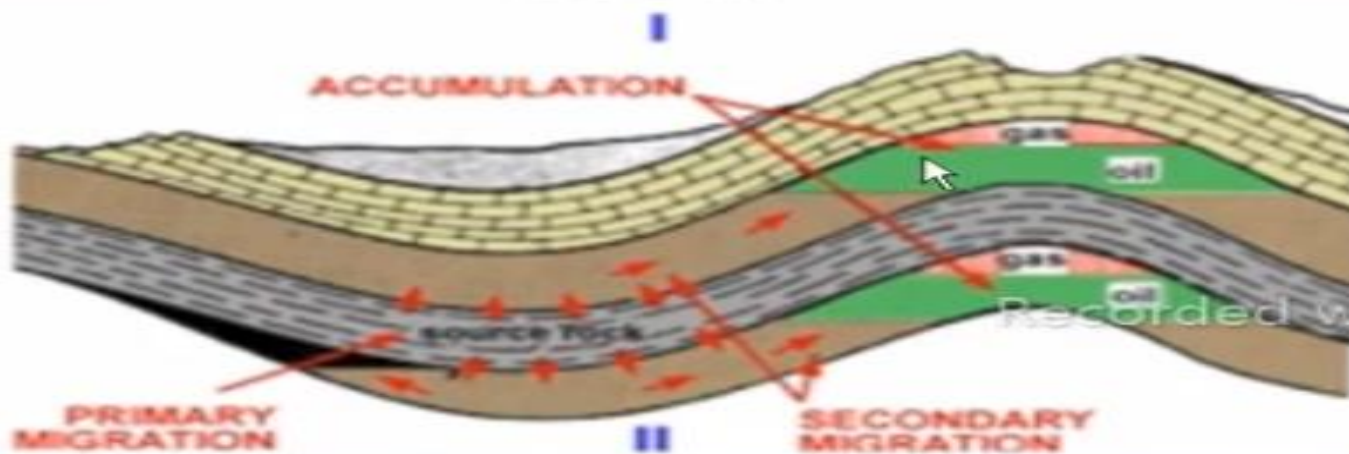
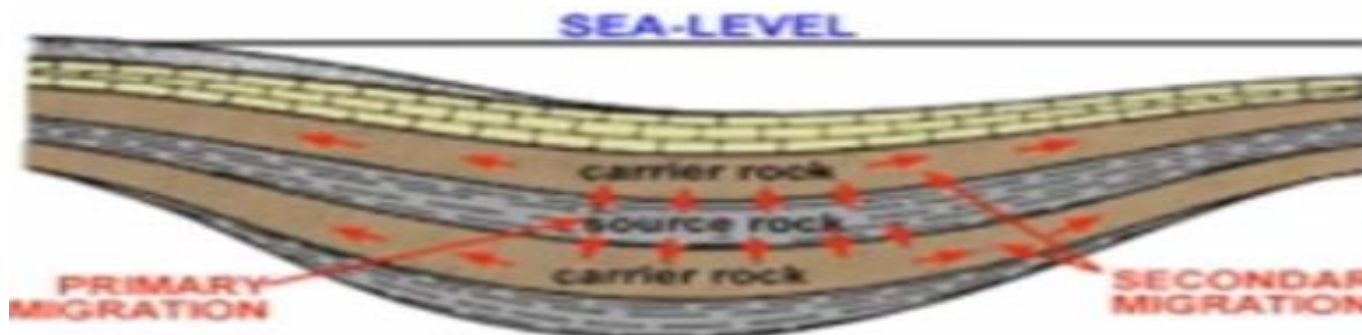

Reservoir Engineering



Reservoir Rock Characteristics



- Storage capacity requires void spaces within the rock and the transmissibility requires that there should be continuity of those void spaces.

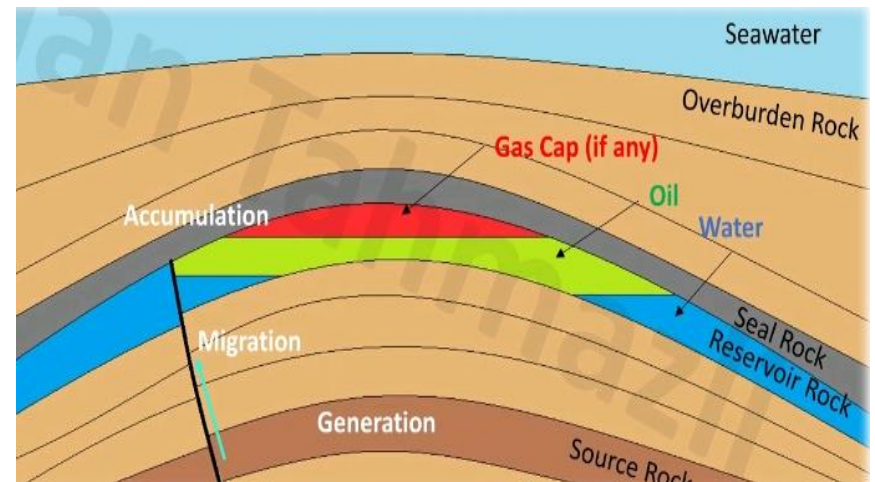
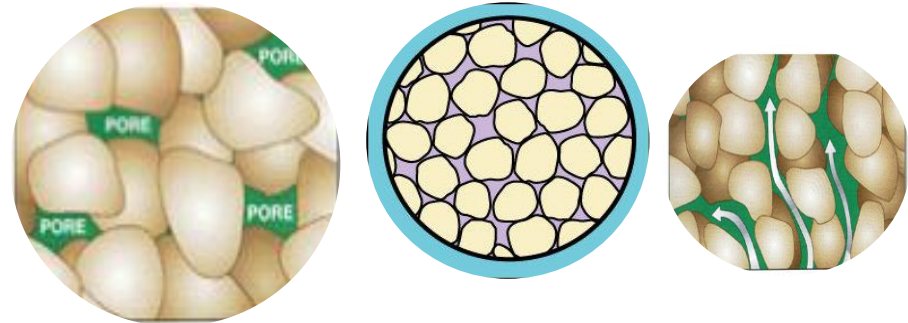

Reservoir permeability



Permeability is a measure of the ability of a porous material to transmit fluid under a potential gradient.

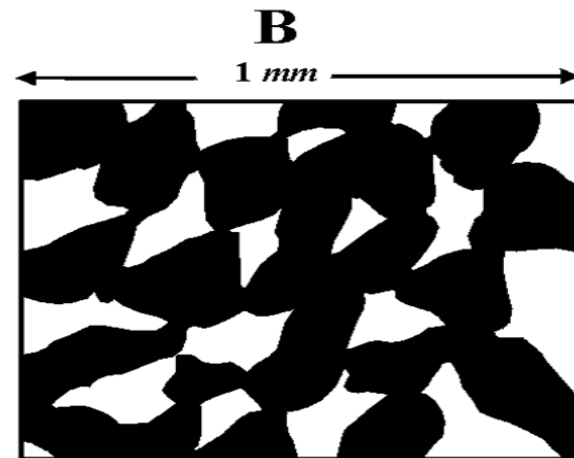
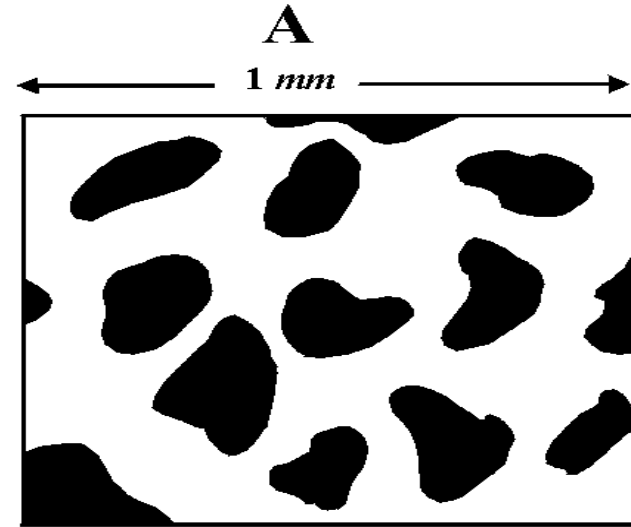

Drive Mechanism



The natural energy of the reservoir used to transport hydrocarbons towards and out of the production wells. There are five important drive mechanisms (or combinations).

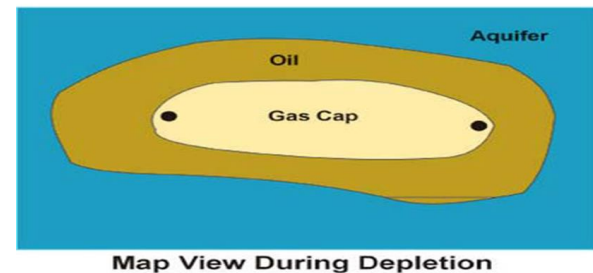
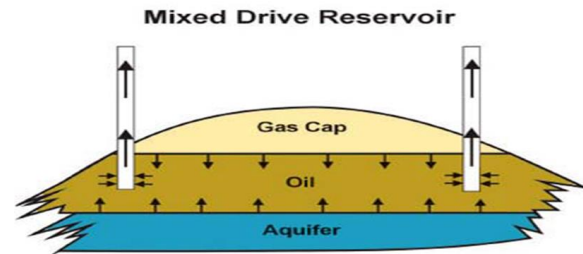
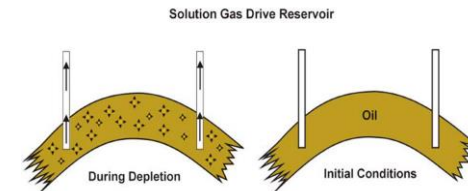
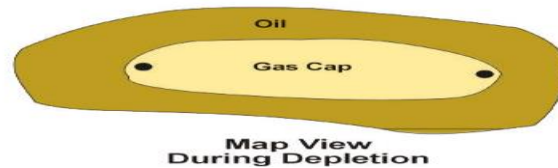
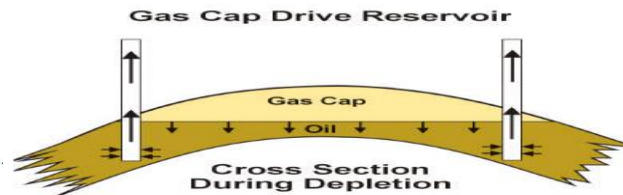
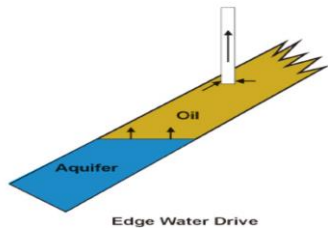
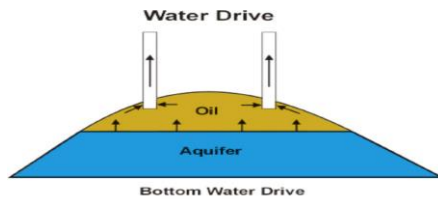

Oil in place Calculation

$$OOIP = \frac{A \cdot h \cdot \phi \cdot (1 - S_w)}{B_{oi}} \quad \text{Eqn.1}$$

$$OGIP = \frac{A \cdot h \cdot \phi \cdot (1 - S_w)}{B_{gi}} \quad \text{Eqn.2.}$$

where

A - reservoir area;
h - payzone thickness;
 ϕ - payzone rock porosity;
 S_w - water saturation;
 B_{oi} - oil formation volume factor at initial conditions;
 B_{gi} - gas formation volume factor at initial conditions;

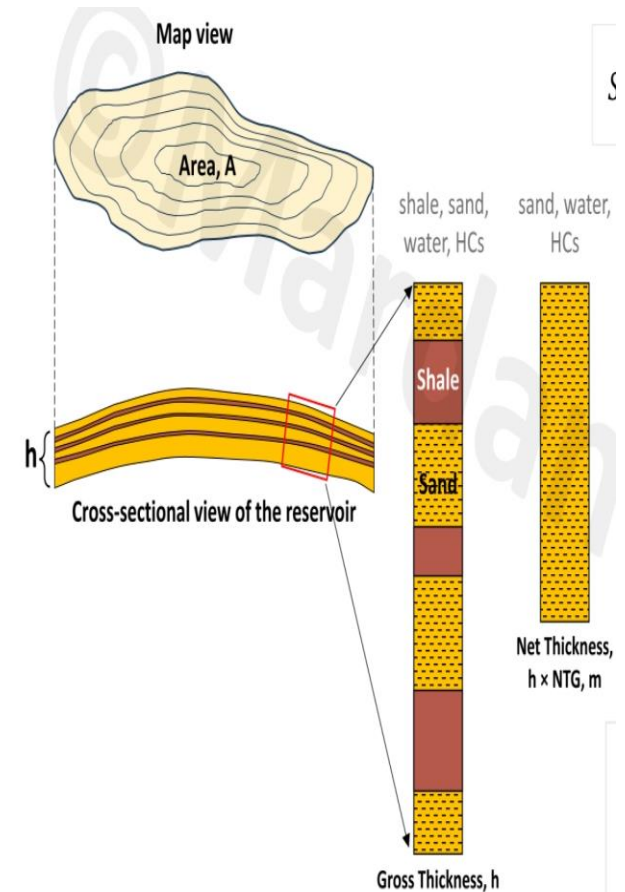

Recovery ranges for each drive mechanism



Drive Mechanism	Energy Source	Recovery, % OOIP
Solution gas drive	Evolved solution gas and expansion	20-30
Evolved gas		18-25
Gas expansion		2-5
Gas cap drive	Gas cap expansion	20-40
Water drive	Aquifer expansion	20-60
Bottom		20-40
Edge		35-60
Gravity drainage	Gravity	50-70

Drilling Fundamentals



Rig types

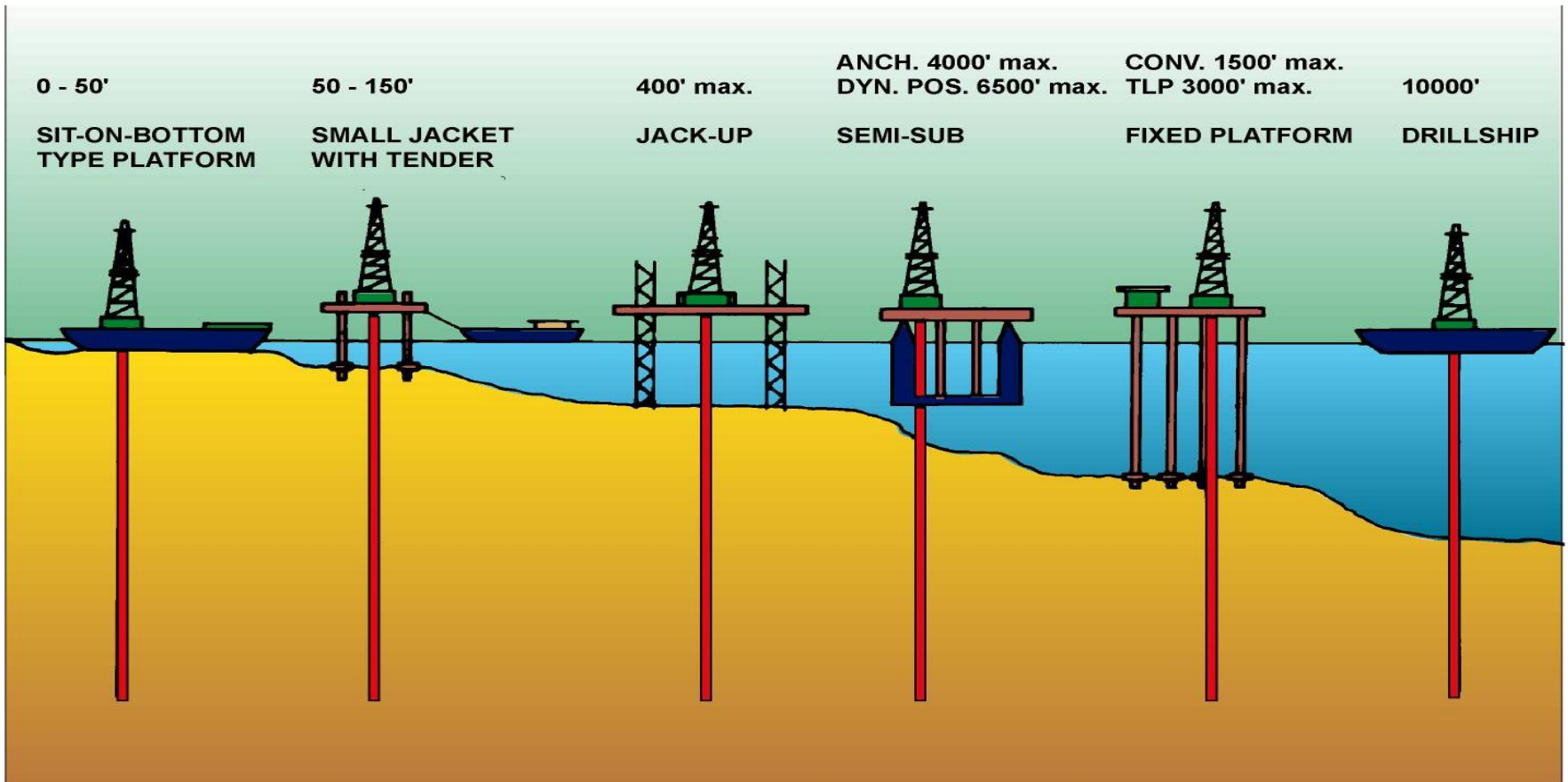

Drilling



- Prime movers
- Hoisting equipment
- Rotating equipment
- Circulating equipment

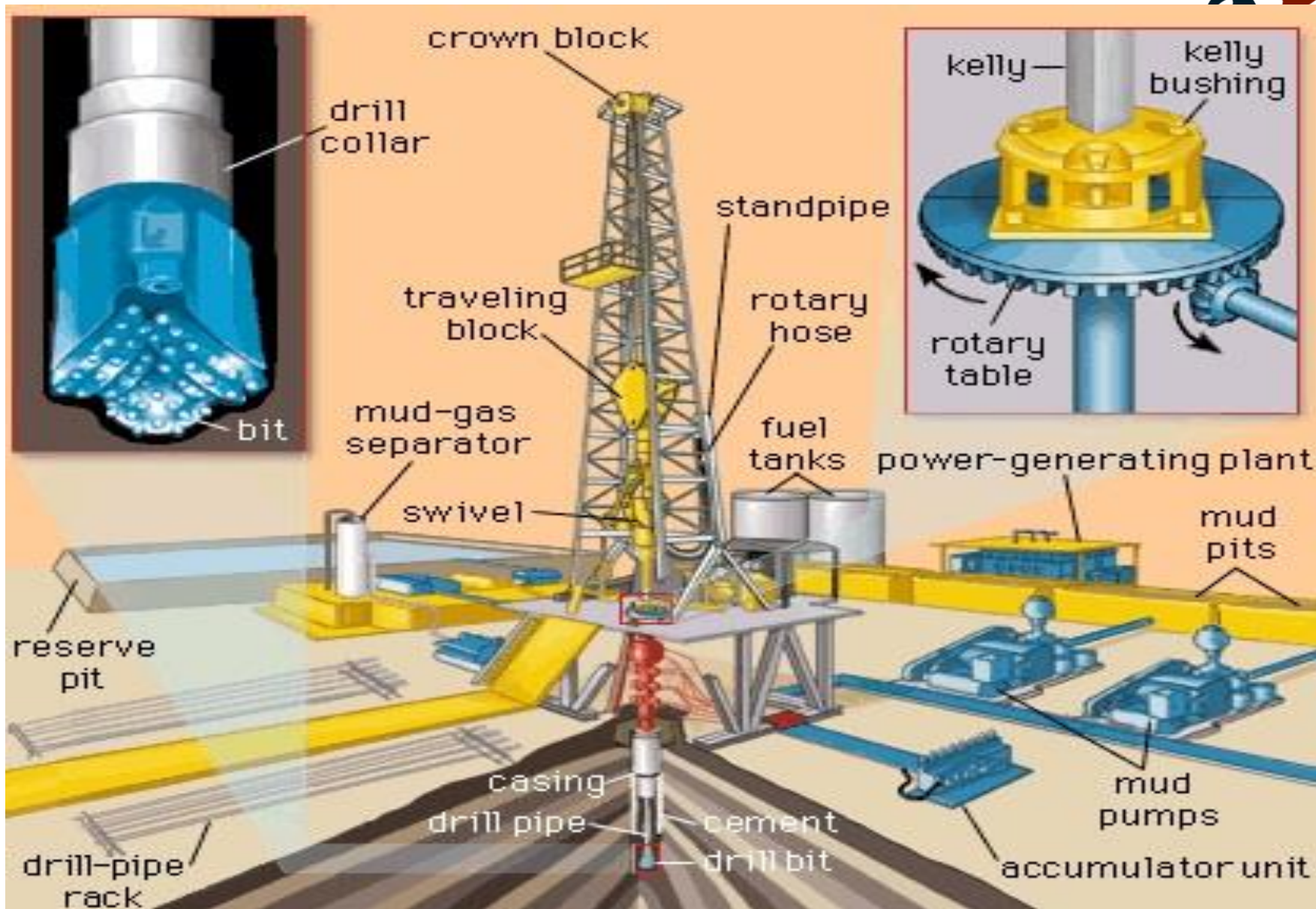

Drilling string

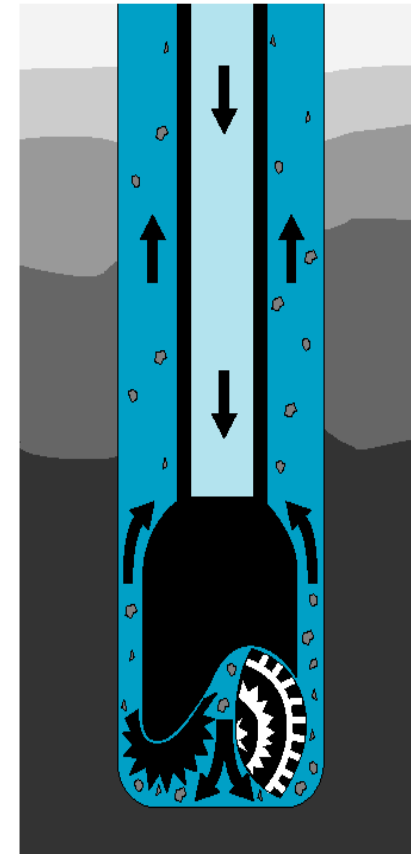

Drill pipe, Collar and bits are called DRILLSTRING



Typical well diagram

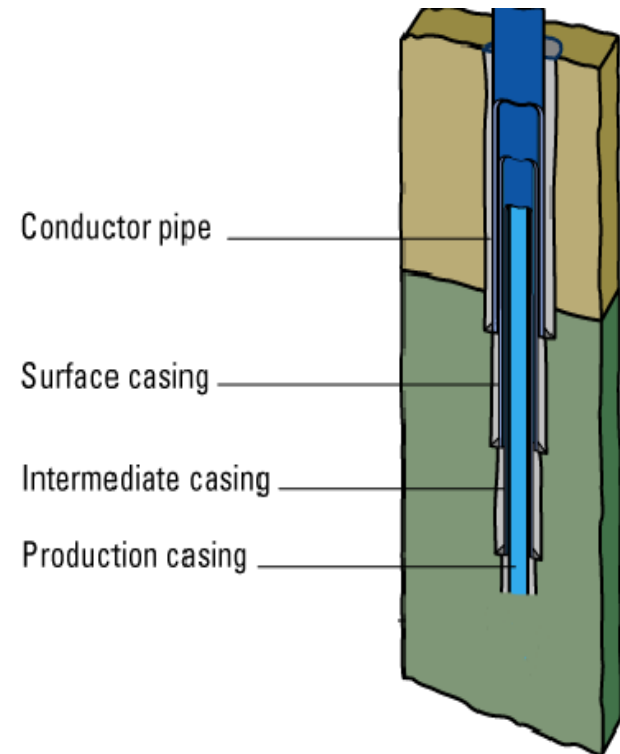
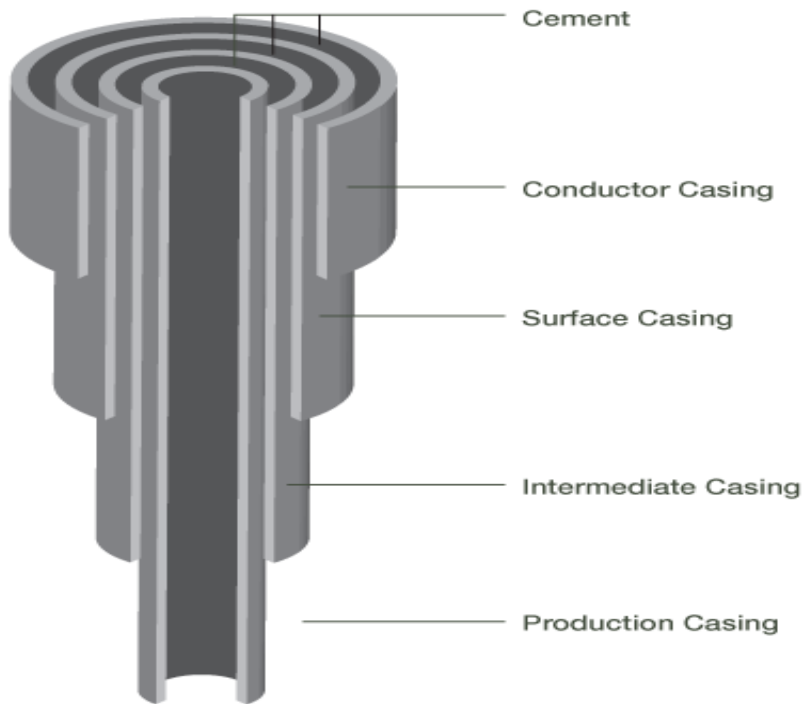

Drilling Problems



- ▶ Stuck pipe
- ▶ Lost circulation
- ▶ Borehole instabilities
- ▶ Mobile formation
- ▶ Undergauge hole
- ▶ Kicks and blowout



Formation evaluation

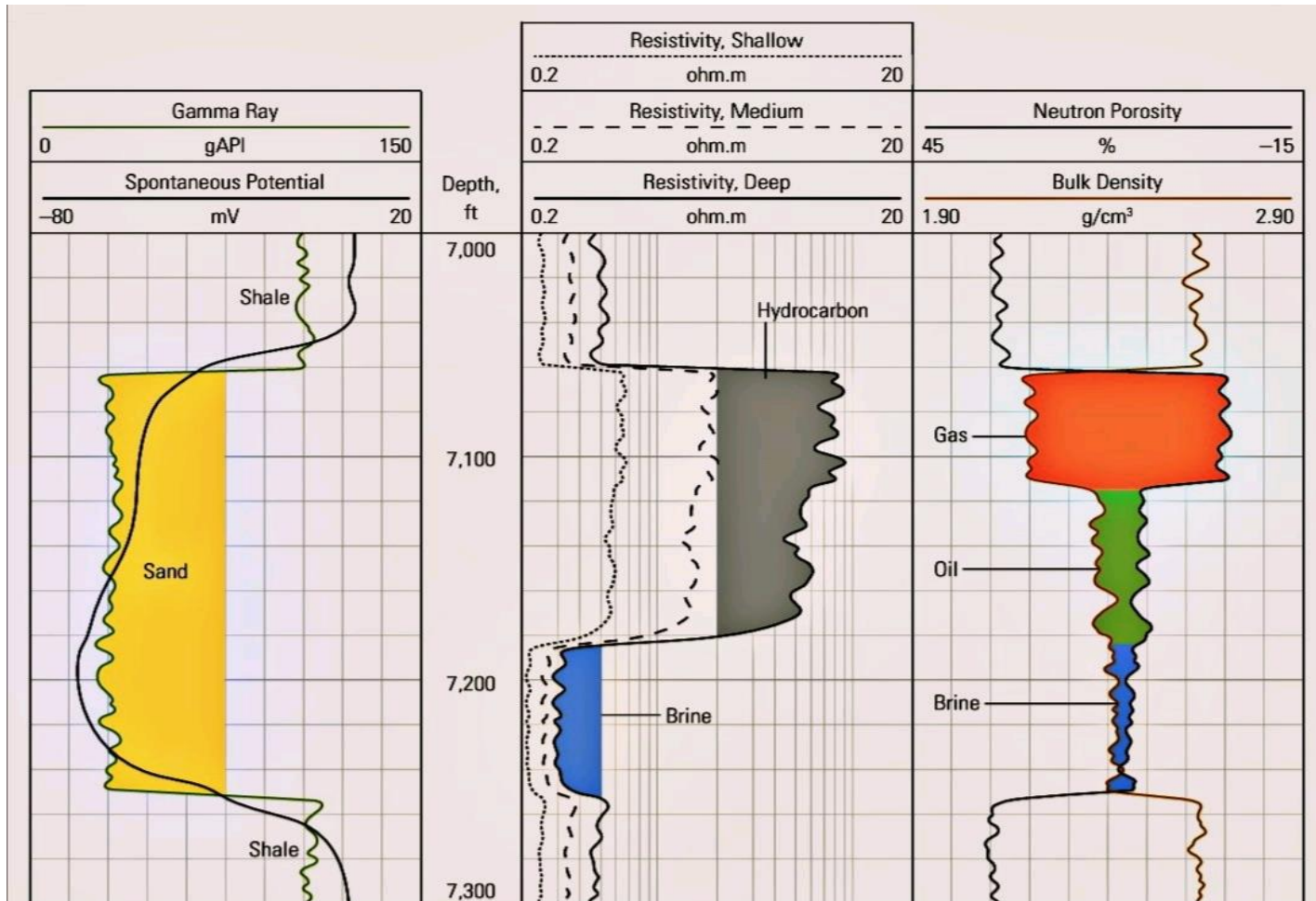

completion

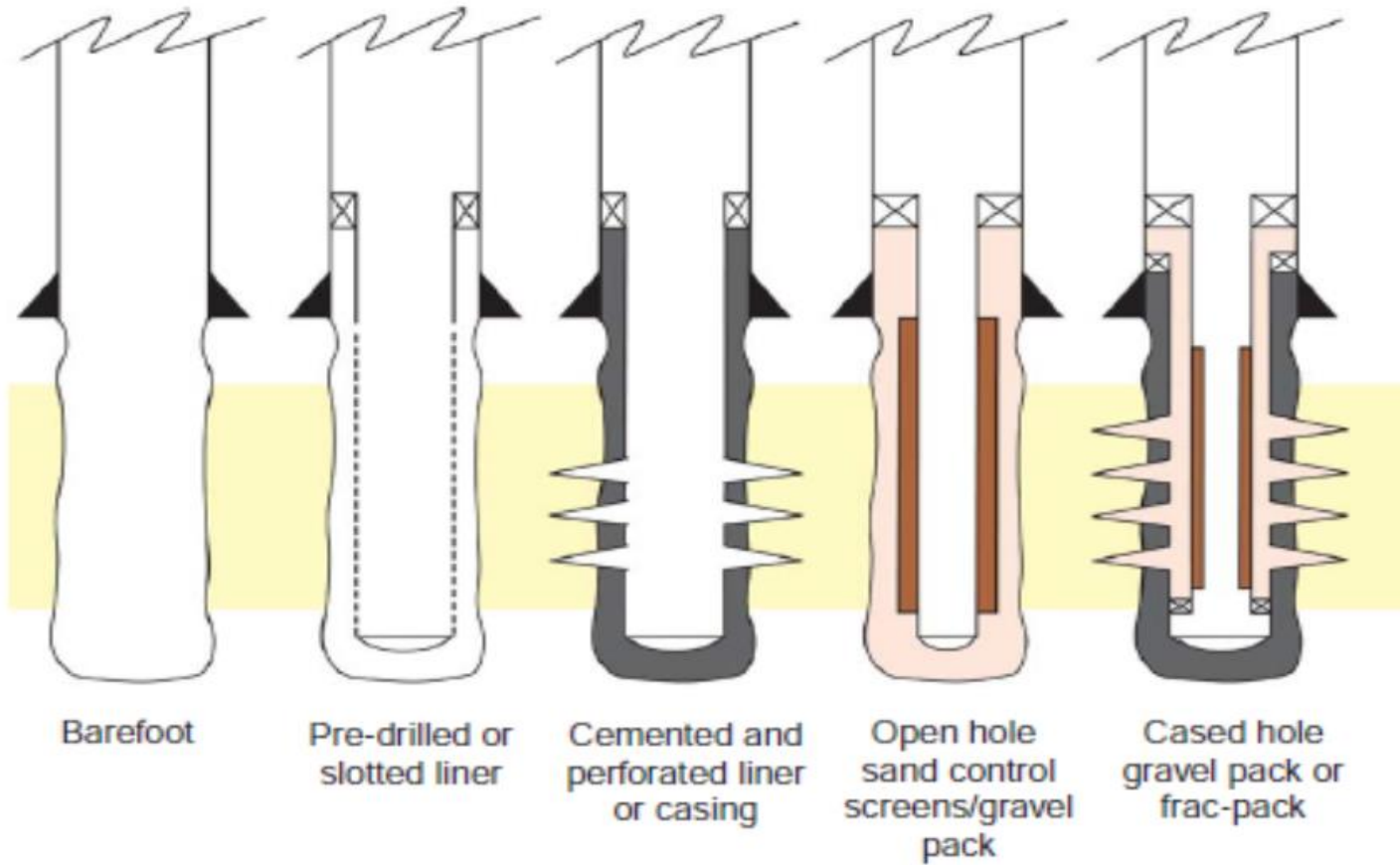

Completion equipment



1. Tubing hanger (Upper annulus barrier)
2. SC-SSSV (Sub-surface barrier)
3. Control line
4. Tubing (Vertical barrier)
5. A annulus (tubing-casing)
6. Gas lift valves (in SPMs)
7. Expansion joint: Tubing Seal Receptacle
8. Anchor seal assembly
9. Production packer
10. Packer sealing element (Lower barrier)
11. Tailpipe
12. WEG

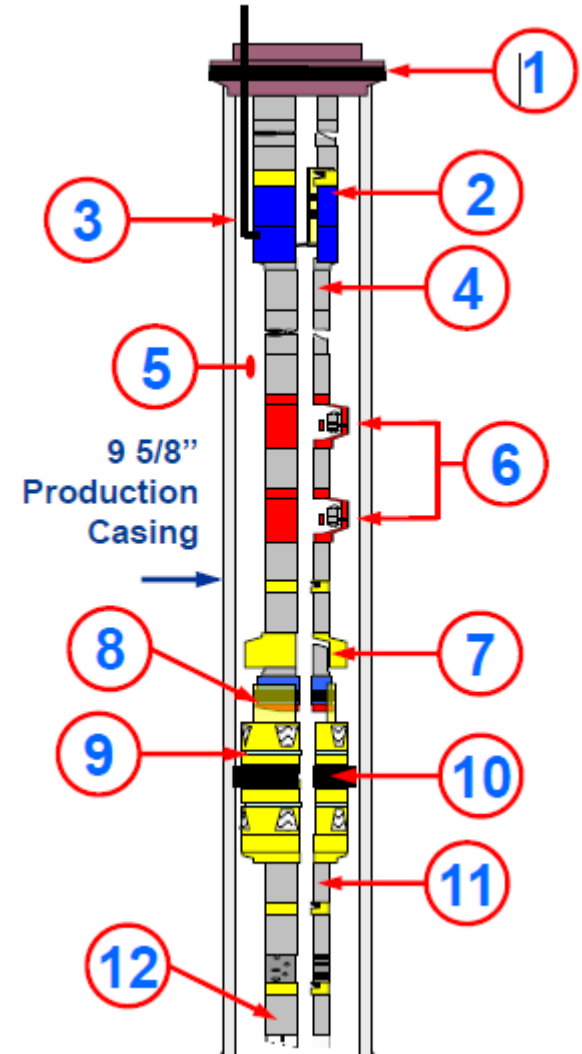

Production Engineering



- (1) The reservoir (Tank)
- (2) The wellbore
- (3) Production tubing
- (4) Wellhead, Xmas Tree & Flow Lines
- (5) Treatment Facilities

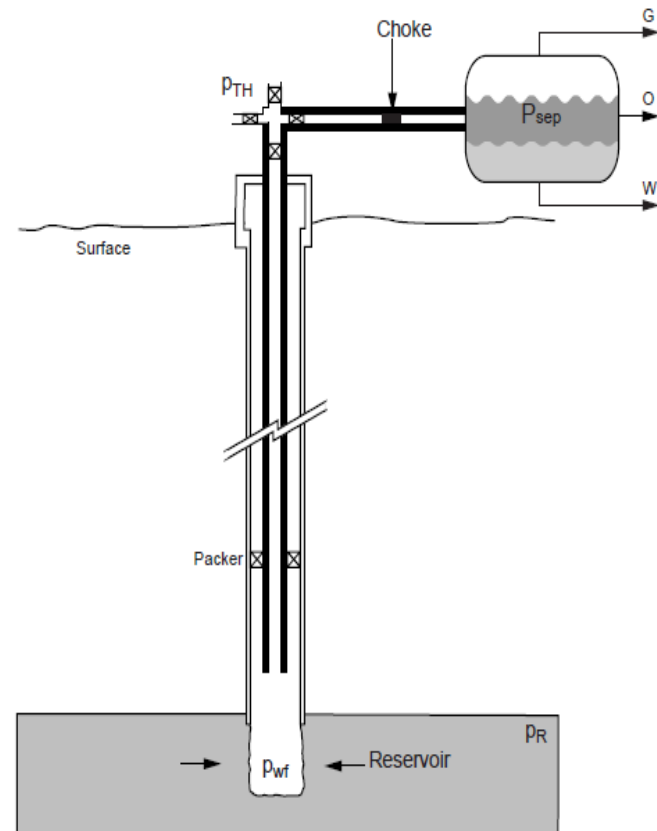

Darcy Equation for Linear, Steady-State, Incompressible Flow

where

q = Volume Flow Rate

k = Permeability

A = Area Perpendicular to Flow Direction

P_1 = Upstream Pressure at Location 1

P_2 = Downstream Pressure at Location 2

μ = Dynamic Viscosity of Flowing Fluid

L = Distance Over Which Pressure Drop ($P_1 - P_2$) Occurs

$$q = \frac{k A (P_1 - P_2)}{\mu L}$$

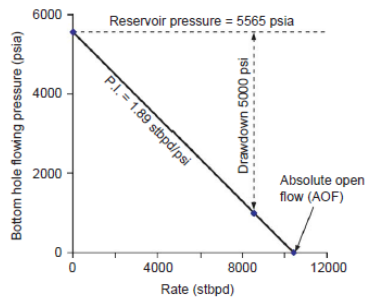
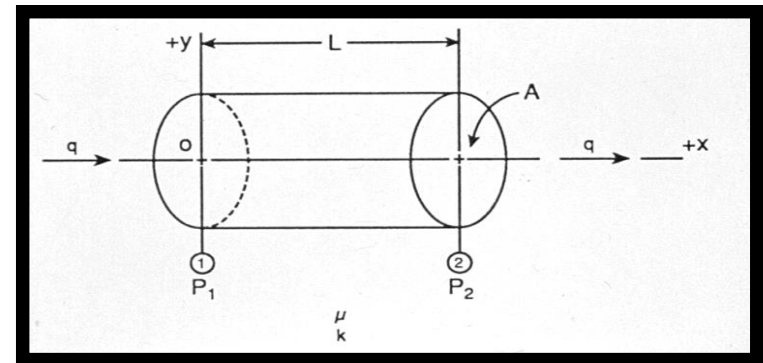

In Flow Performance Relationship - IPR Curves

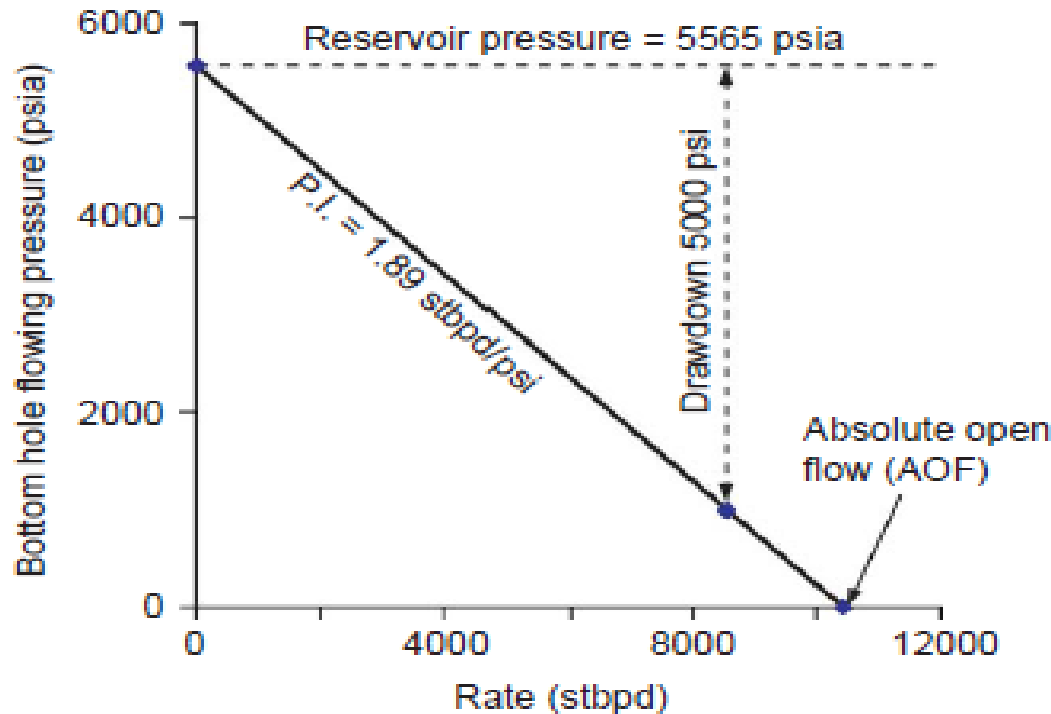

$$J = \frac{0.00708k_o h}{\mu_o B_o \ln(0.472r_e/r_w)} = \frac{q_o}{(\bar{p}_r - p_w)}$$

Vertical Lift Performance (VLP)



$$\left(\frac{dp}{dL}\right)_t = \left(\frac{dp}{dL}\right)_f + \left(\frac{dp}{dL}\right)_{el} + \left(\frac{dp}{dL}\right)_{acc}$$

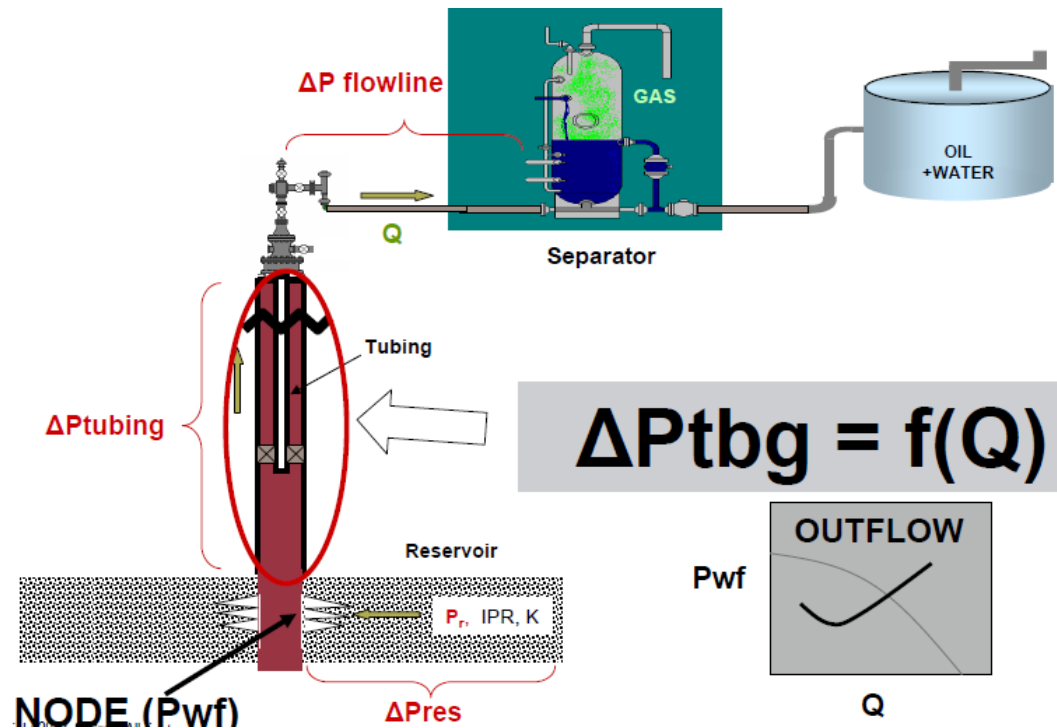

Outflow Correlations

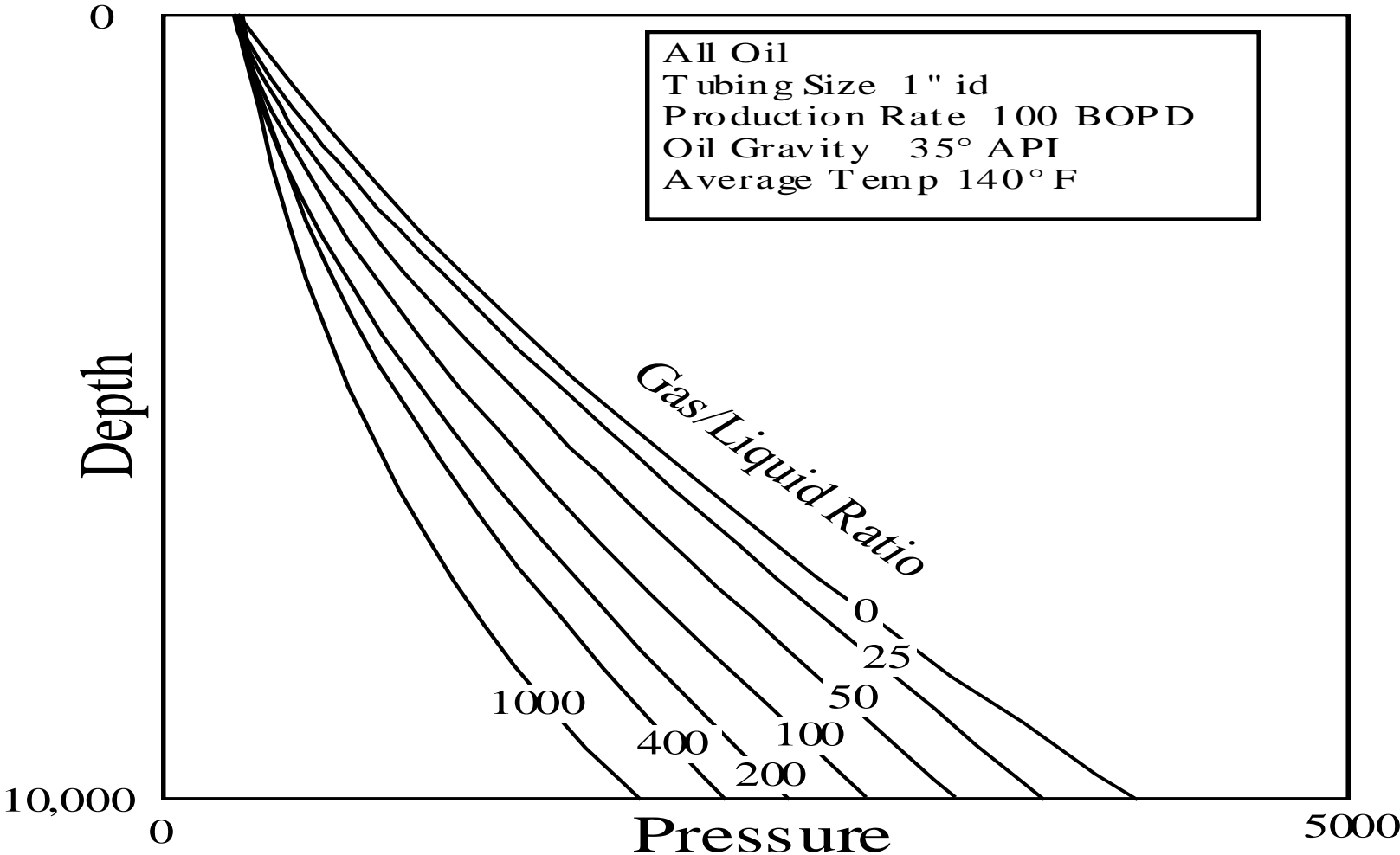

Production Calculation

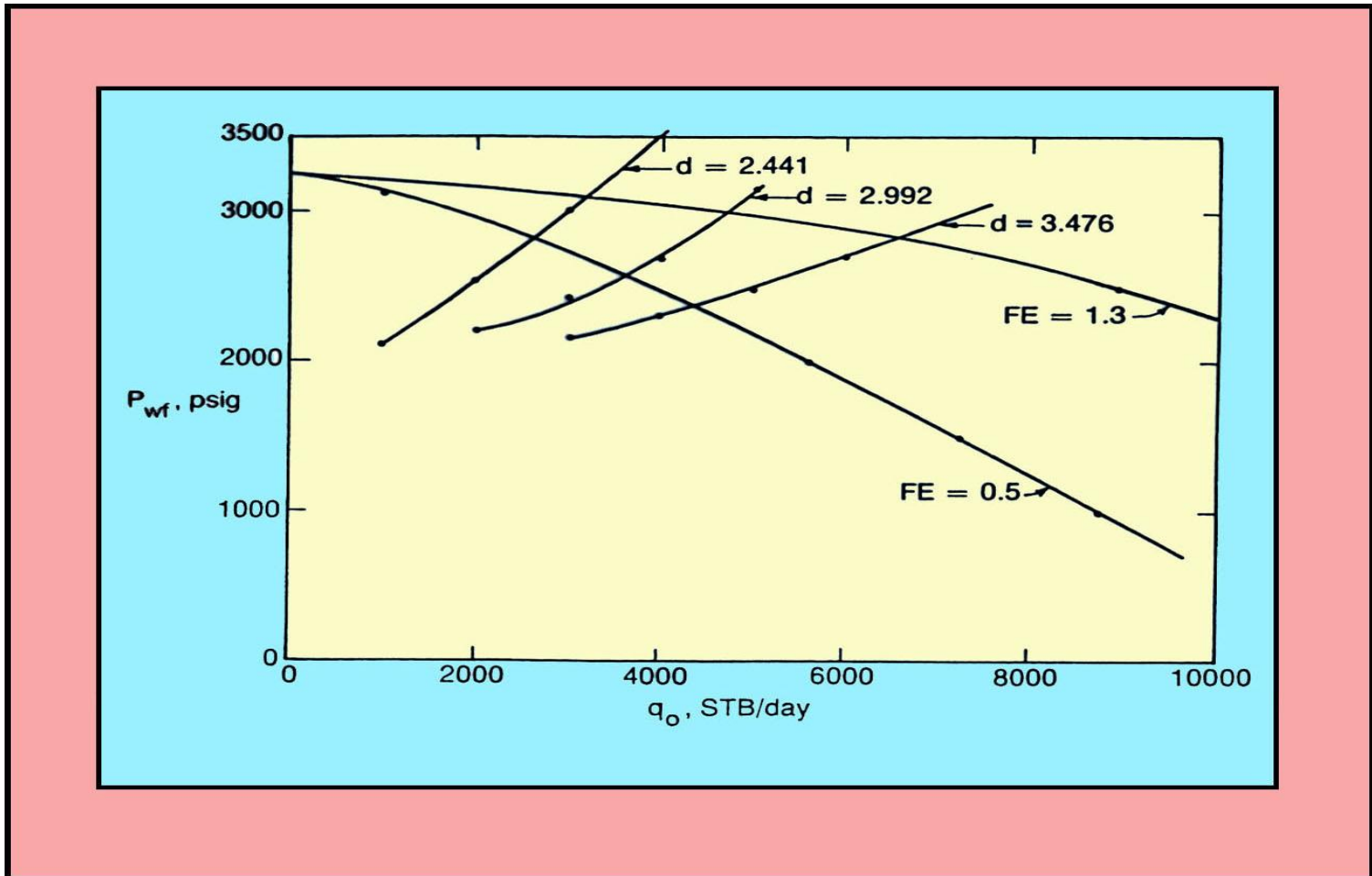

Artificial lift definition

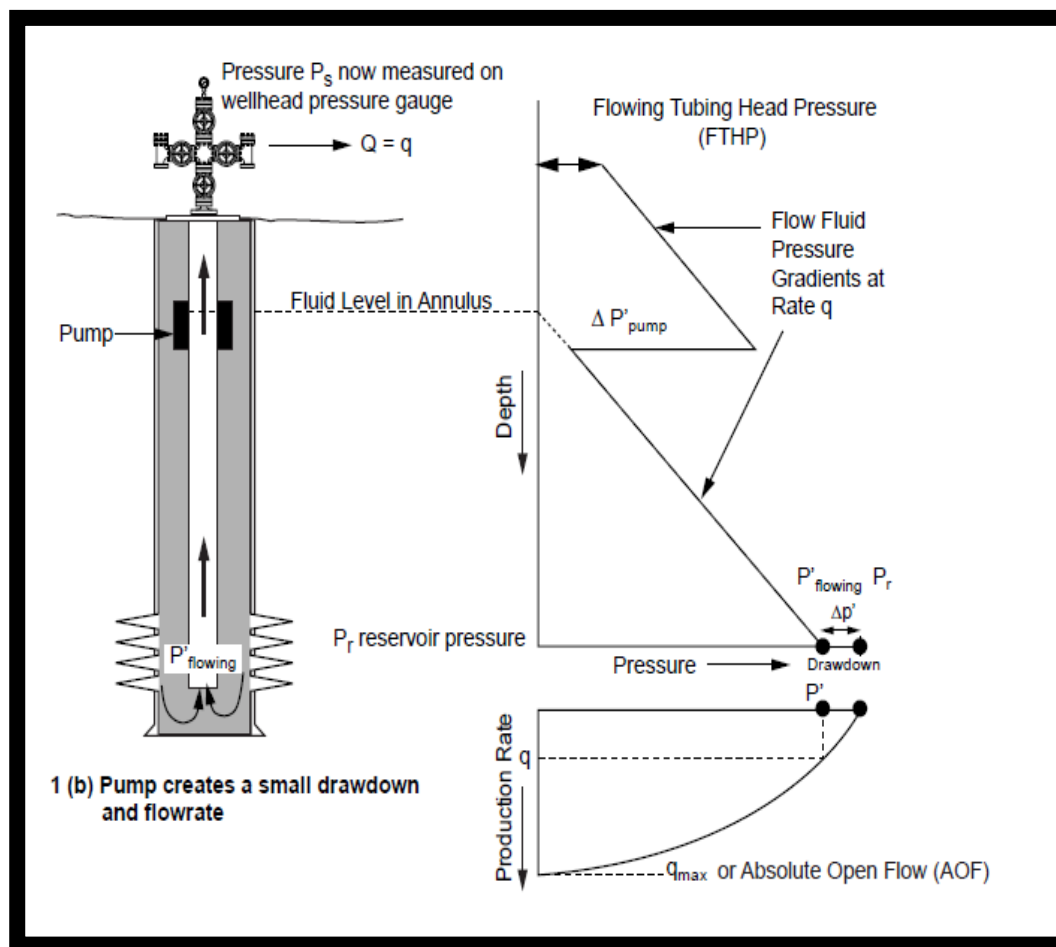

Artificial lift types

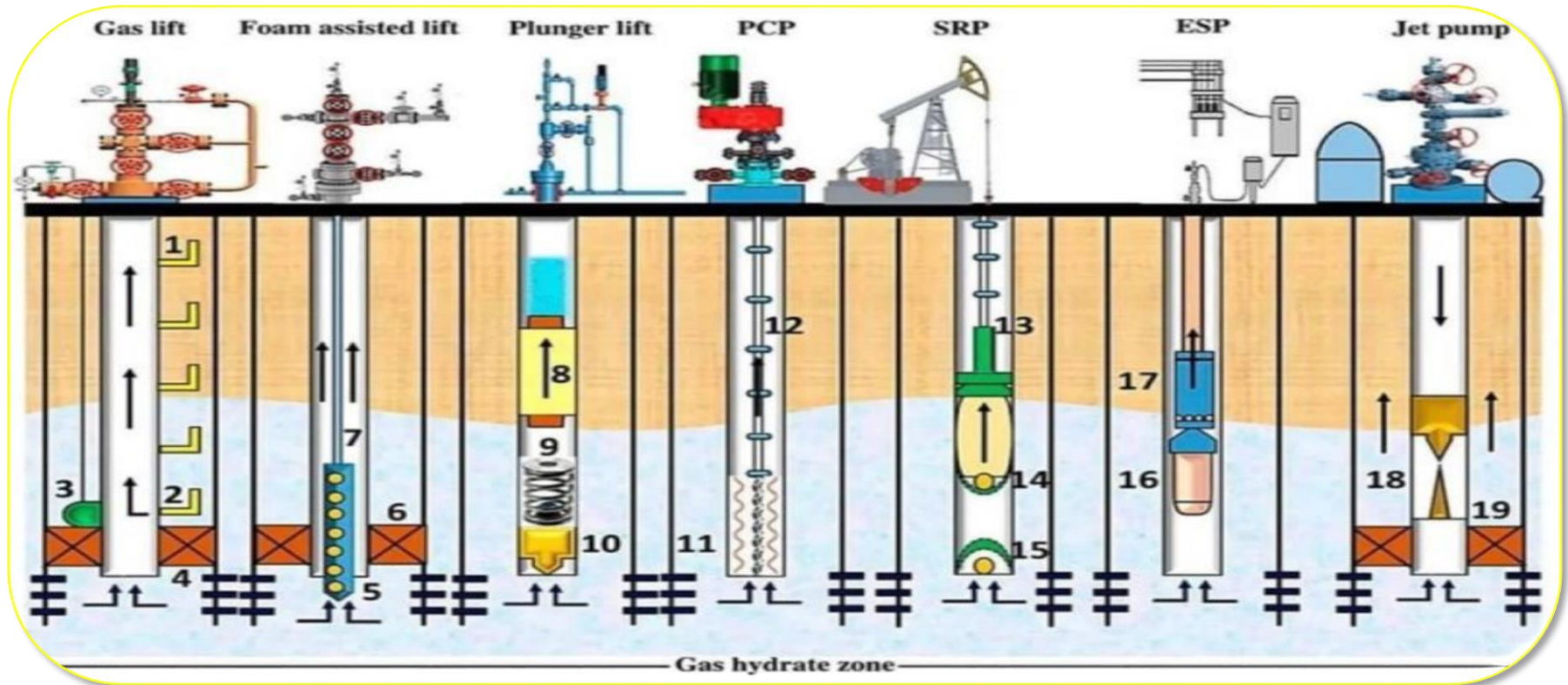

Well operations

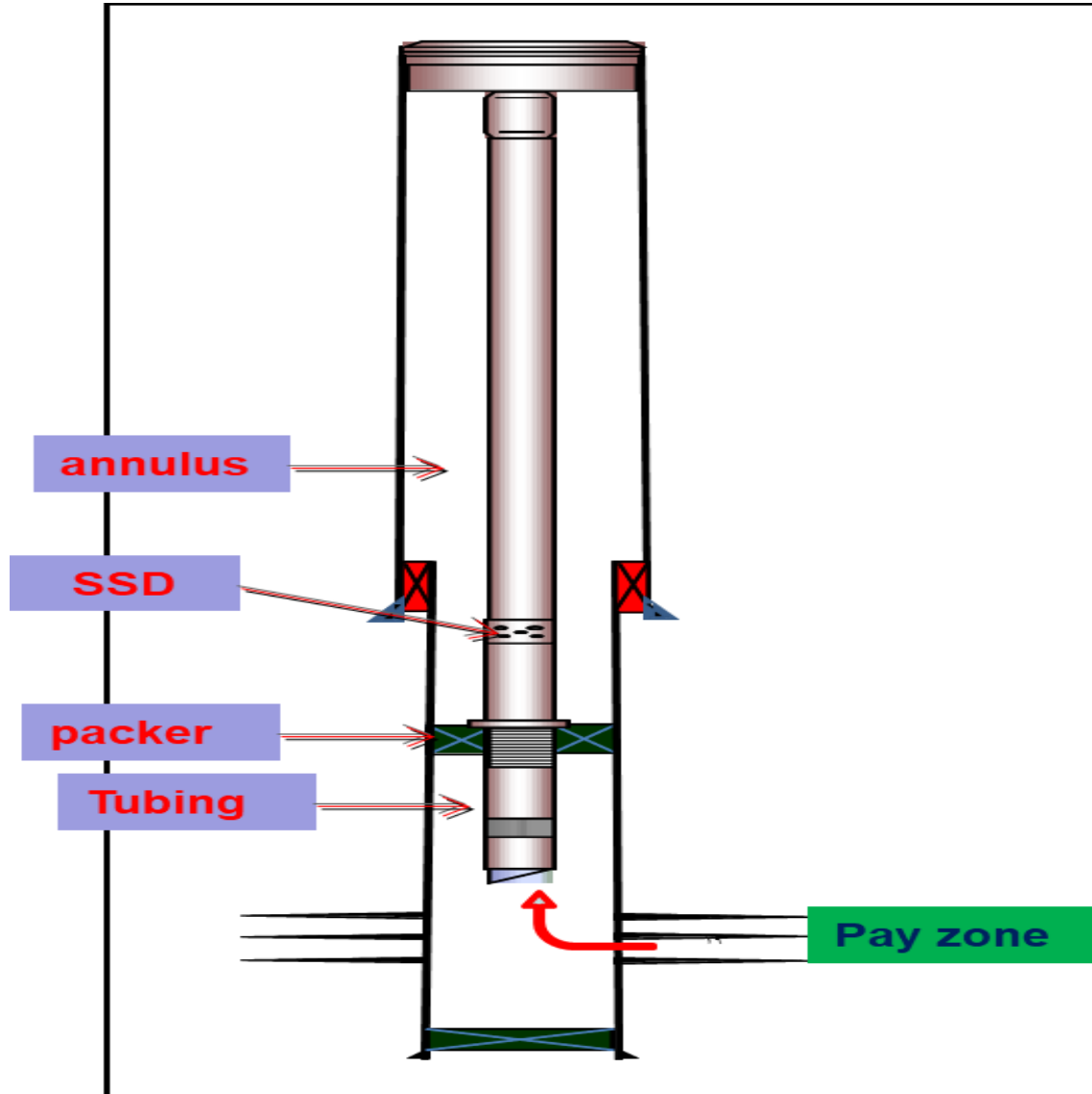

Well operations through the life of a well



- 1.Data acquisition
- 2.Integrity monitoring and repair
- 3.Water or gas shut-off
- 4.Debris removal and sand control
- 5.Sidetrack and well Deeping
- 6.Tubing replacement
- 7.Flow assurance
- 8.Stimulation
- 9.Perforating
- 10.Using Artificial-lift
- 11.Convert well to injector



Workover types

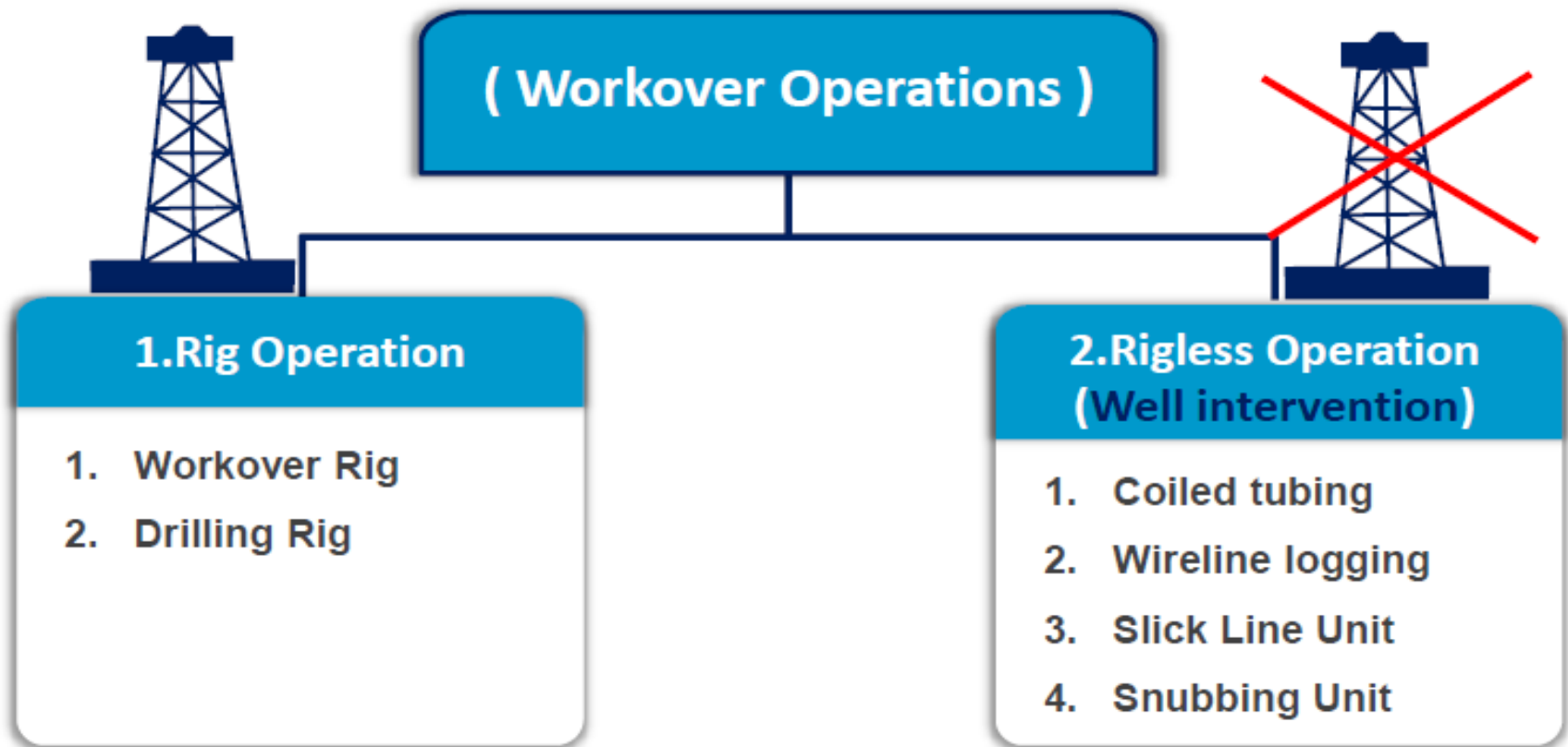

Rigless

1. Coiled Tubing Unit (flexible coiled tubing)
2. Snubbing Unit
3. Wireline logging Unit
4. Slick Line Unit



wireline

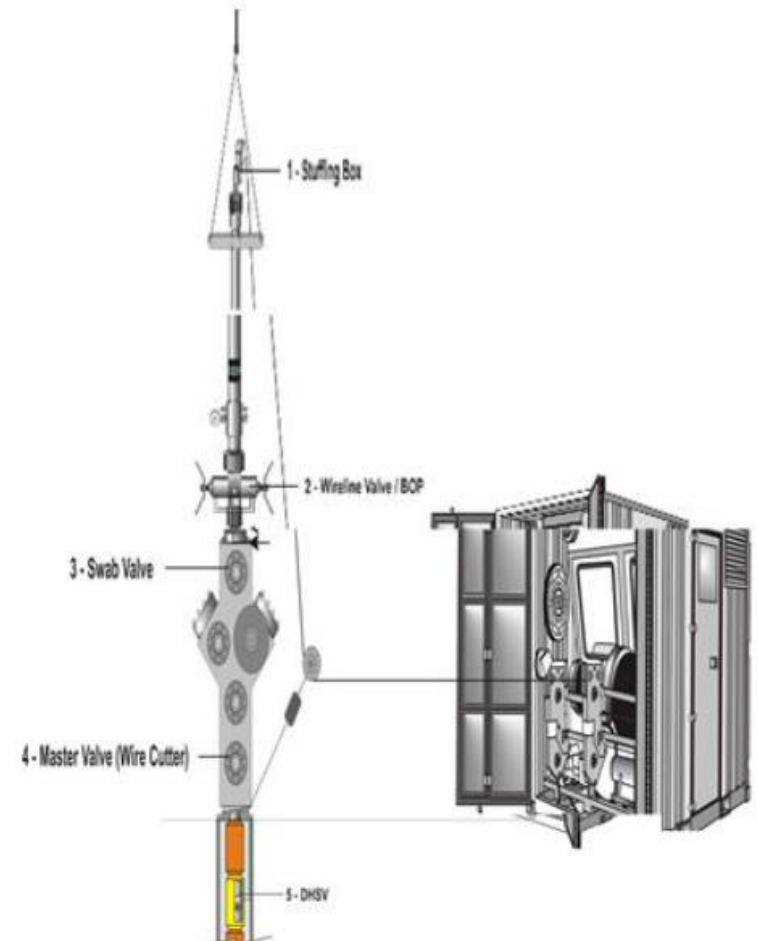
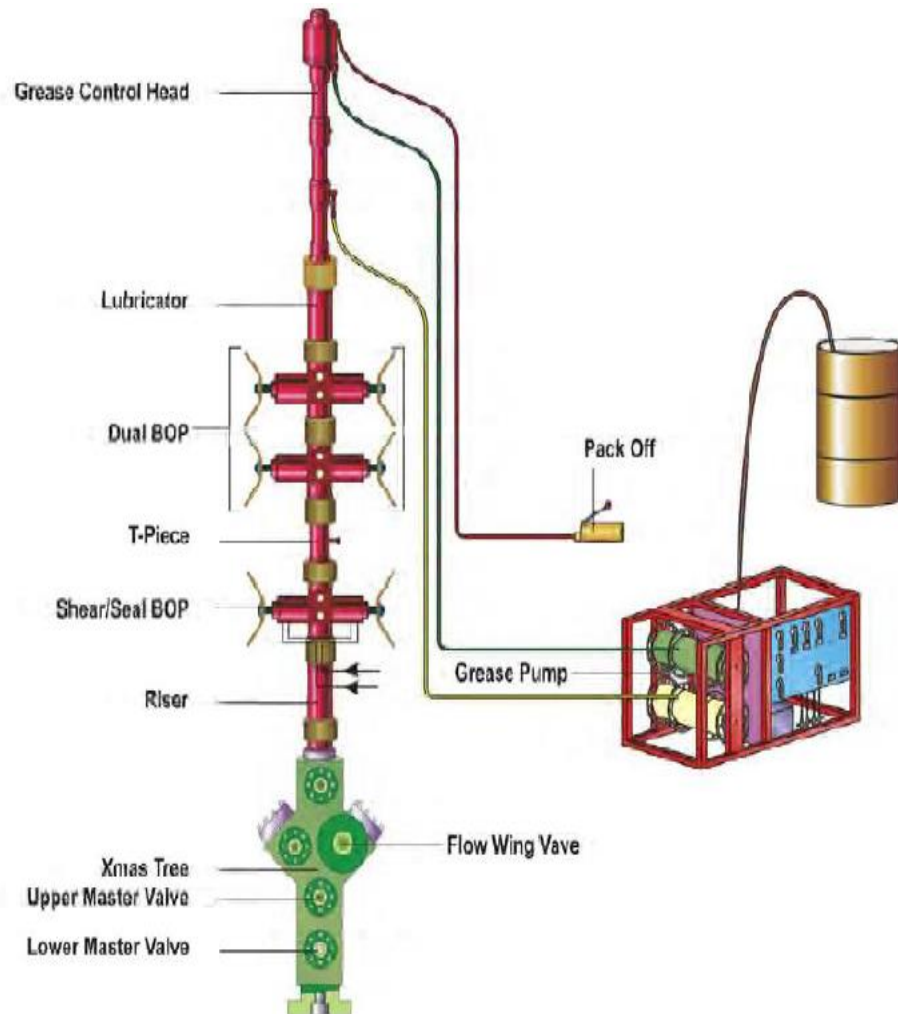

Coil tubing

1. Drilling
2. Logging
3. Perforating
4. Stimulation (Acidizing , fracturing)
5. Nitrogen lifting
6. Removal sand from wellbore
7. Wellbore cleanout (asphalt...etc)
8. Remedial cementing
9. Setting and retrieving bridge plugs
10. Removal Wax , Scale and hydrate plugs
11. fishing
12. Etc

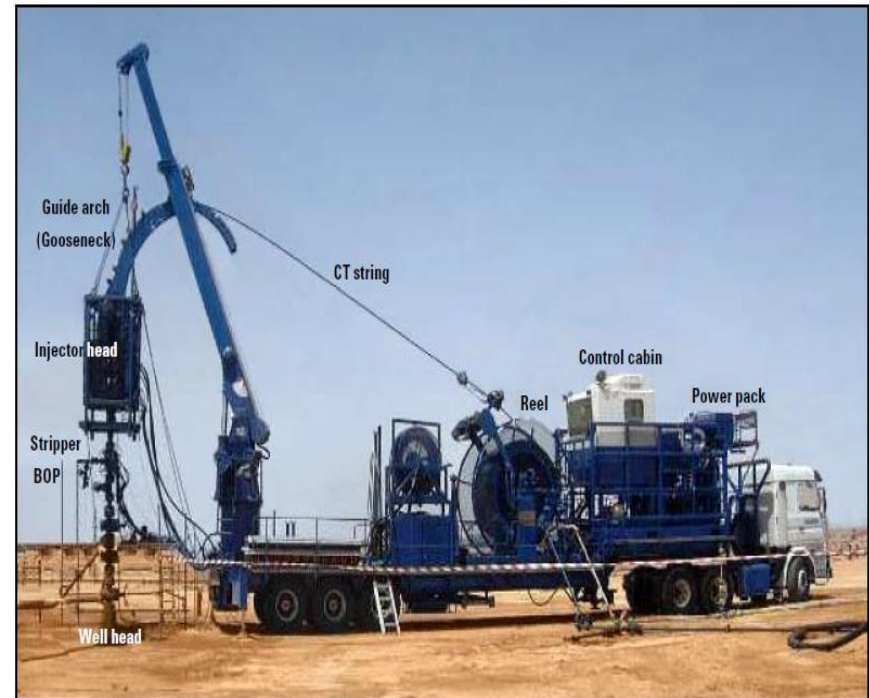



Thanks